

ELEVATOR	Elevator drive Rack and pinion Maximum passengers 30 Total base unit weight 15,656 lbs (7,116 kg) Capacity 6,000 lbs (2,727 kg)
CAR/GATES	Car weight 5,600 lbs (2,545 kg) Maximum car speed 300 ft/min (45.73 m/min) Interior car dimensions 12'4" L x 4'8" W x 7'2" H (3.76 m x 1.42 m x 2.18m) Landing gates Swinging Gates
TOWER	Maximum tower height 900' (274.32 m) Consult Factory for Greater Heights Dimensions of tower 38" W x 28" L x 60" H (.97 m x .71 m x 1.52 m) Weight of tower 300 lbs (136 kg) Wall ties Adjustable Strut Tie-in intervals 30' (9.14 m)
MOTOR/POWER	Electrical motor 30 HP 22.4 KW Power required 33 KVA, 480 VAC, 60 Hz, 3Ø Motor control Across The Line Electrical outlet 120 VAC In Car Base disconnect Circuit Breaker in NEMA 4 Enclosure Full load current 39.5 Amps Traveling cable Multi-Conductor Type W – Tower Height Plus 30' (9.14 m)
BRAKES	Brake Spring Set, Electrical Release Multiple Disc Brake Safety overspeed governor Centrifugal Actuated Multiple Friction Disc Brake Stopping distance accuracy Operator Controlled Brake torque 175 ft./lbs. (102 Nm)
COUNTERWEIGHT	Weight of counterweight 5,600 lbs (2,545 kg) Counterweight wire ropes 5/8" (15.88 mm) 6x25 XIP-IWRC Length of counterweight ropes ... 2 x Tower Height Plus 30' (9.14 m)

STANDARD BASE UNIT

- Fully assembled enclosed car
- Overspeed governor
- Two manually operated vertically bi-parting car gates
- Control and limit switches
- 20' of tower for 0 lifting height
- Hand lever control
- Counterweight & Cathead Assembly
- Base fence enclosure
- Base disconnect box
- Buffer stand and springs
- Power cord guide trailing wheel assembly
- GFI Receptacle in Car
- Interior Car Lighting

OPTIONAL FEATURES & SERVICES

- Base platform and stairs
- Building landing gates
- Communication or signal system
- Gin pole with winch for tower erection
- Preventative Maintenance
- Drop Test & Test Weights

Foundation Dimensions

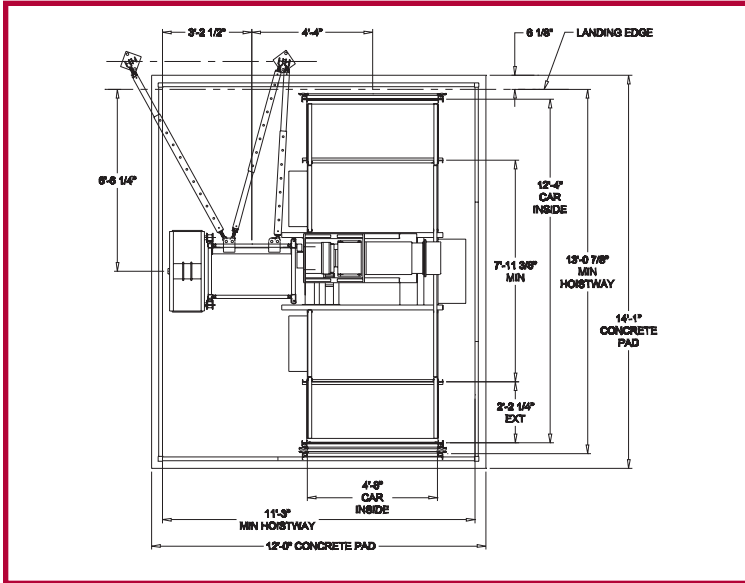

Basic Elements

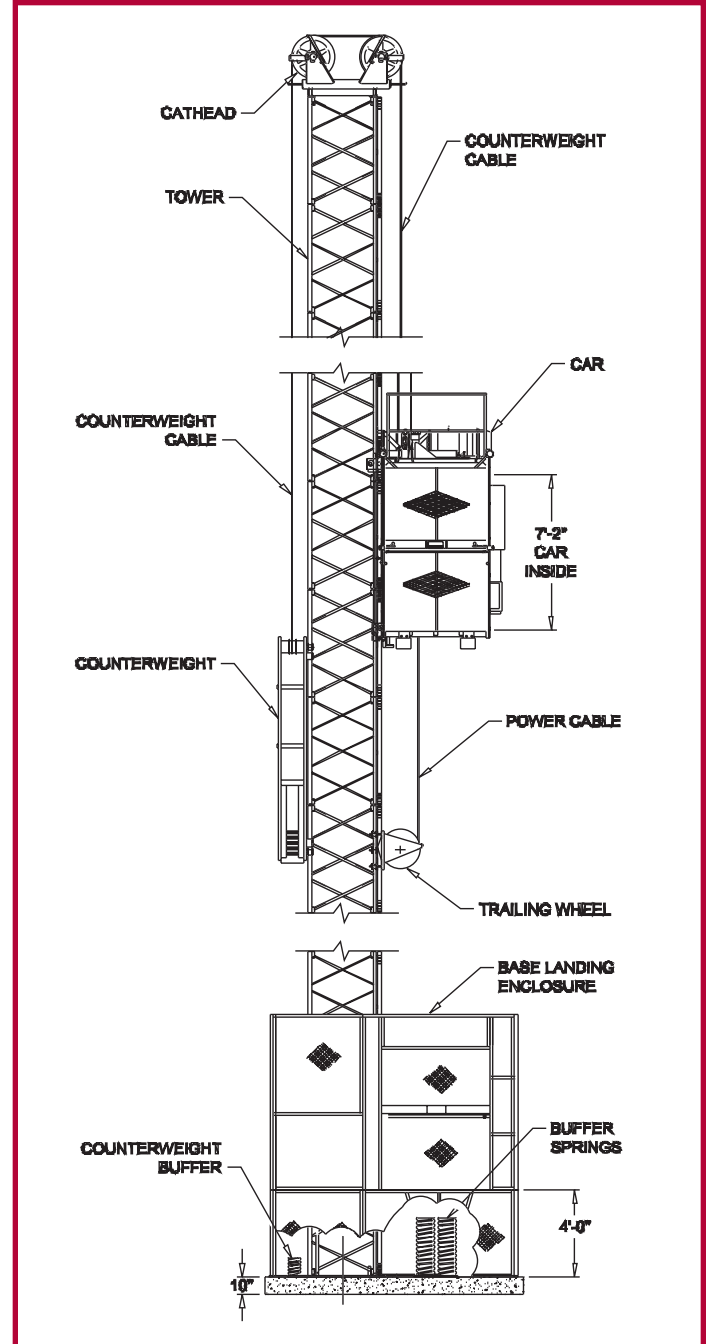

Wall Tie Detail

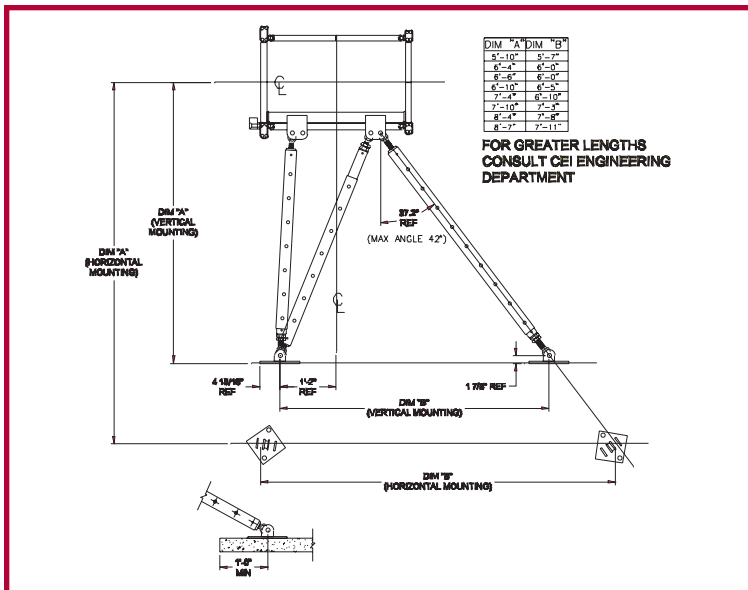

Dimensions are typical, please consult with your sales representative for specific configurations.

Elevators are designed to comply with ANSI A10.4 and / or A17.1 Part XV. Use of products must conform to safe practice and applicable statutes, regulations, codes, and ordinances. Drawings are illustrative only and do not necessarily depict exact configurations of products offered at a particular time.

Foundation is 10" thick 4000 PSI concrete pad with a single mat of #4 rebar on 12" centers 3" from the bottom.